



Basic Mechanical Engineering

Prof. Yogiraj Deshmukh

Assistant Professor

Department of Applied Sciences & Engineering

*Hope Foundation's International Institute of
Information Technology, I²IT*

UNIT III

Manufacturing Processes

Introduction to Manufacturing Processes and their Applications (Casting, Forging, Sheet metal working and Metal joining processes), Description of Casting process: Sand casting (Cope & Drag). Sheet metal Forming, (shearing, bending, drawing), Forging (Hot working and cold working comparison), Electric Arc welding, Comparison of Welding, Soldering, Brazing

Manufacturing Process

It involves transforming a raw material from its original state to a finished state by changing its shape or the properties of the material in a series of steps.



Metal Casting

“ Casting: It is a manufacturing process in which part of desired shape is obtained **by pouring molten metal into cavity** of required shape

” It is one of the oldest manufacturing process (around 6000 year old, Egyptians were first to use castings)

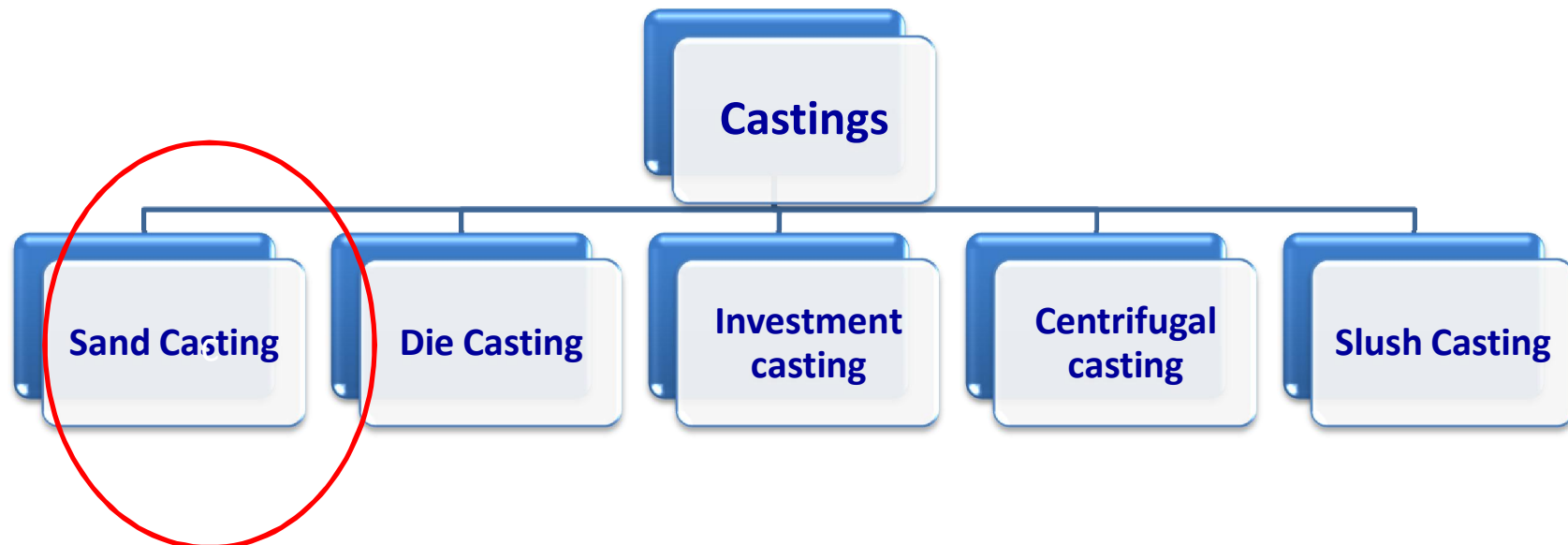

Basic terminology in **SAND CASTING** process:

1. Mould
2. Pattern
3. Core
4. Mould box
5. Mould material
6. Pouring cup
7. Pouring basin
8. Sprue
9. Runner
10. Gate
11. Riser
12. Ladle

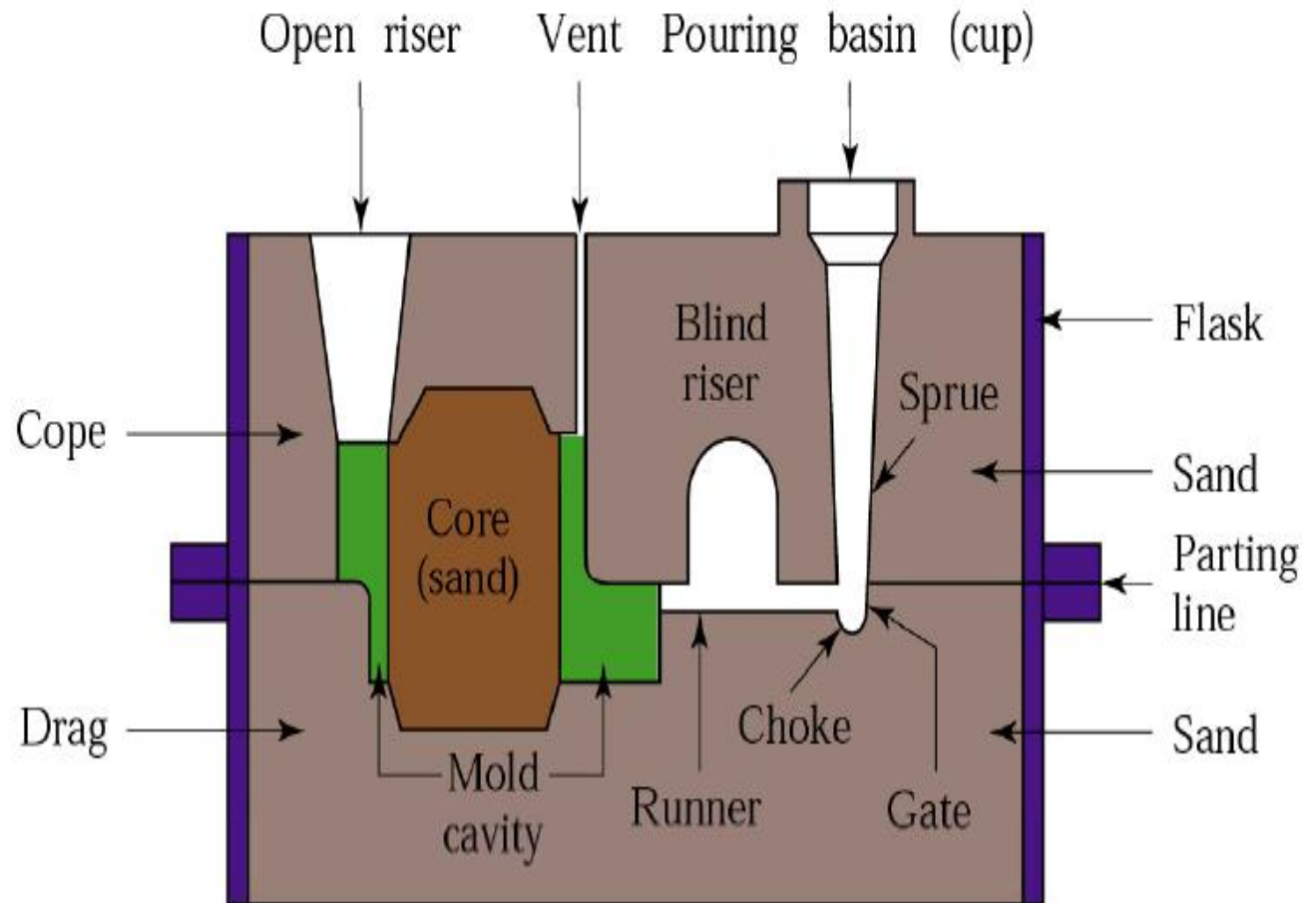

Metal Casting: Sand Casting

“ Steps in Sand Casting:

1. Pattern Making:

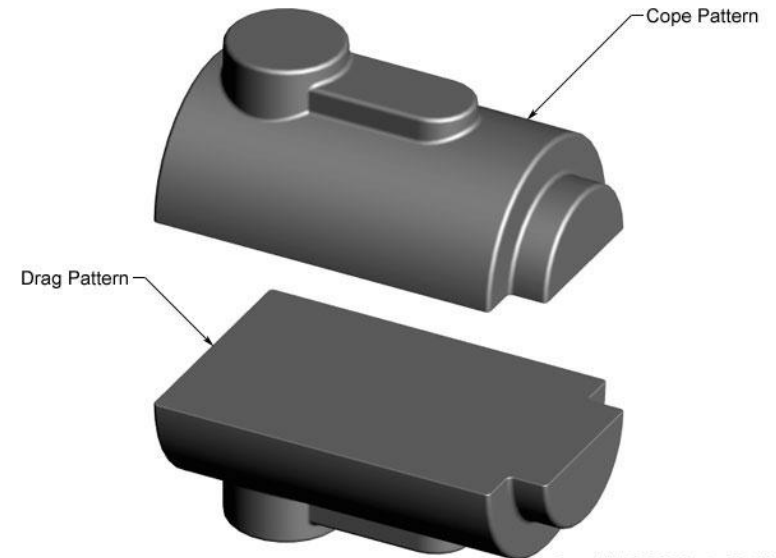
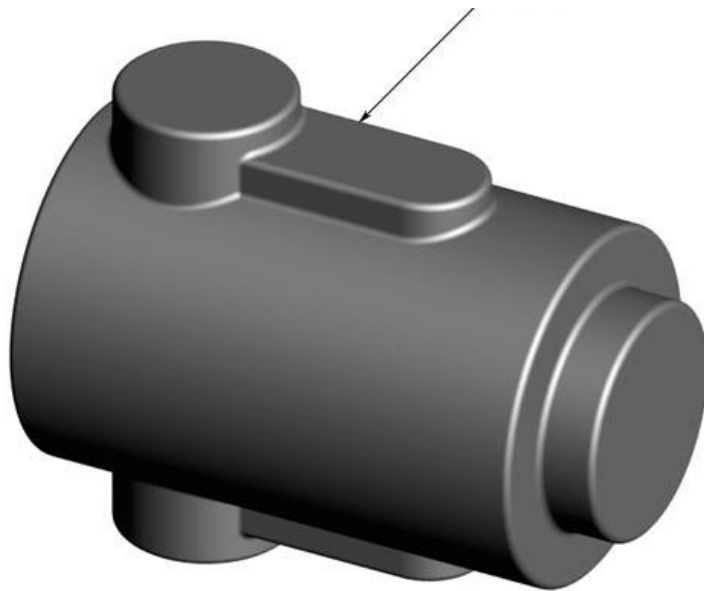

Metal Casting: Sand Casting

“ Steps in Sand Casting:

2. Mould Making:

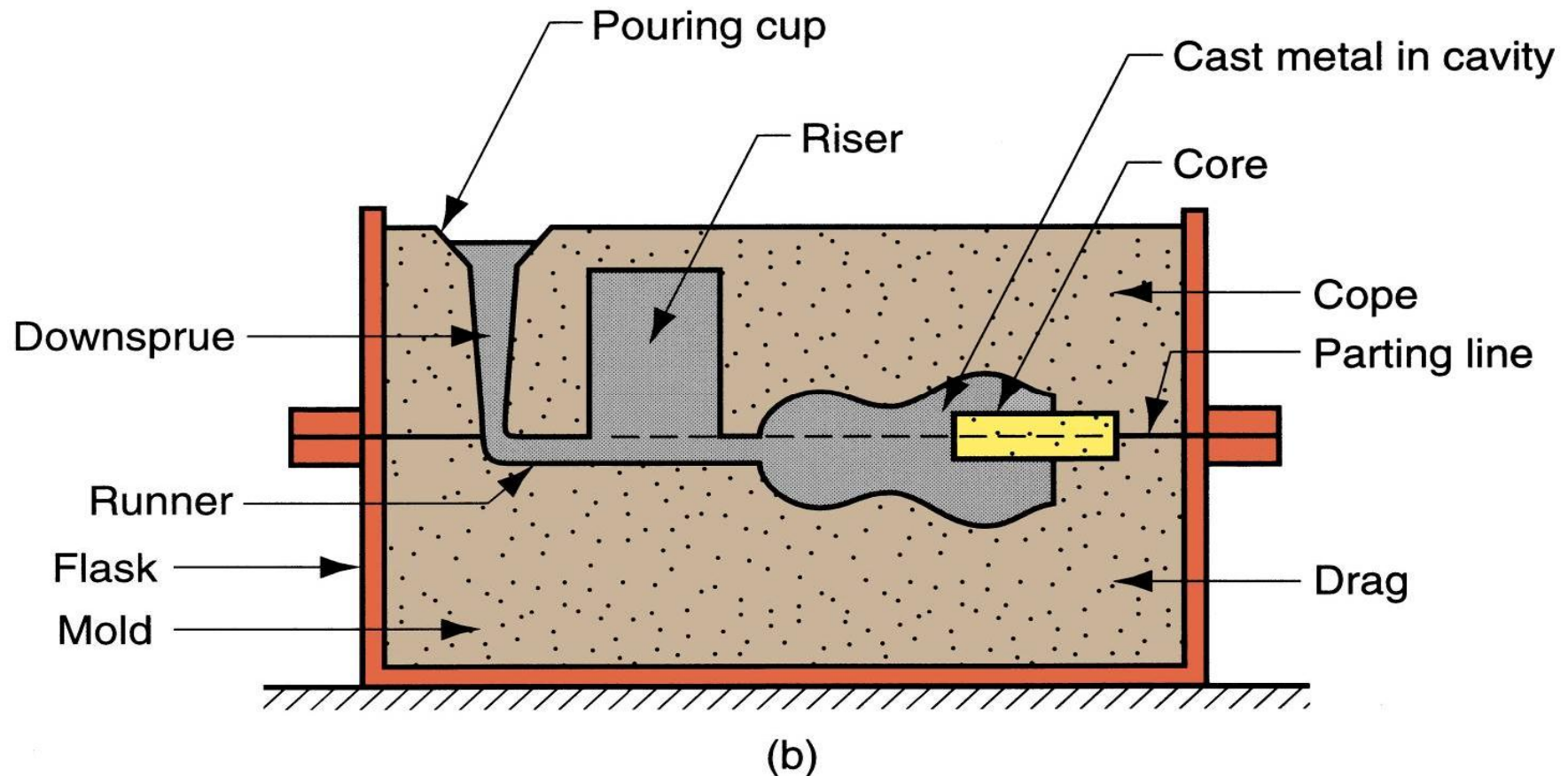

Metal Casting: Sand Casting

“ Steps in Sand Casting:

3. Core Making:

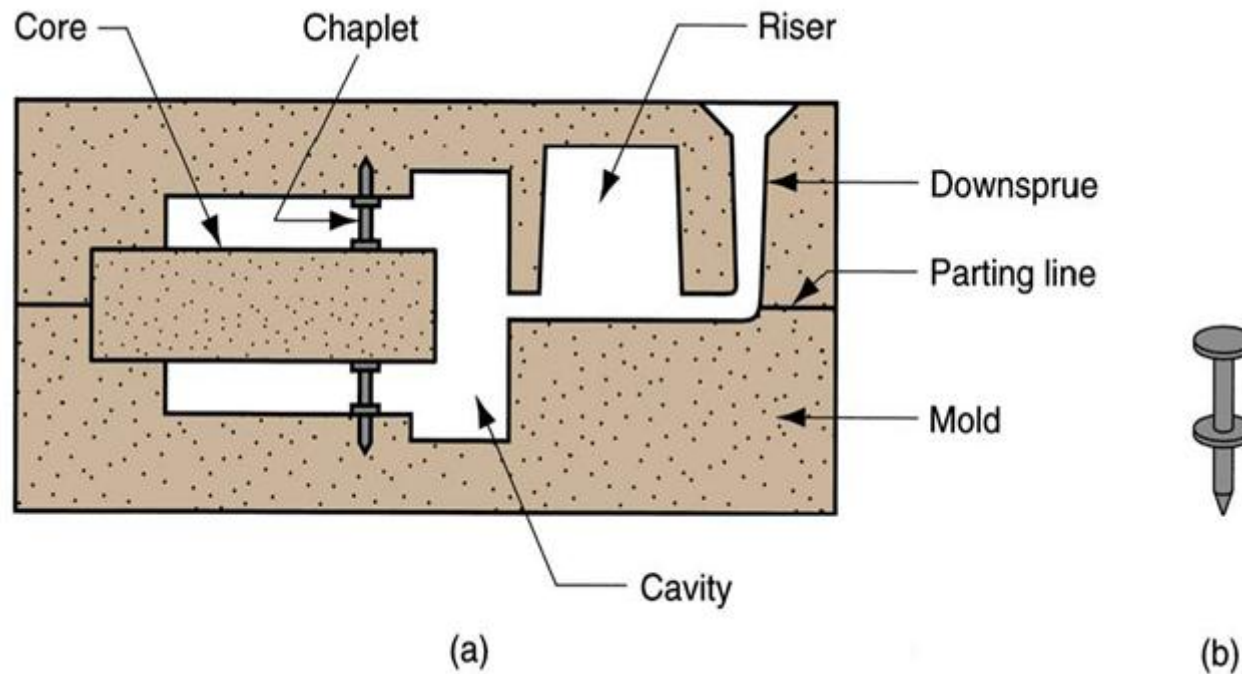

Metal Casting: Sand Casting

“ Steps in Sand Casting:

4. Metal Melting and Pouring:



Metal Casting: Sand Casting

“ Steps in Sand Casting:

5. Solidification
6. Finishing
7. Inspection

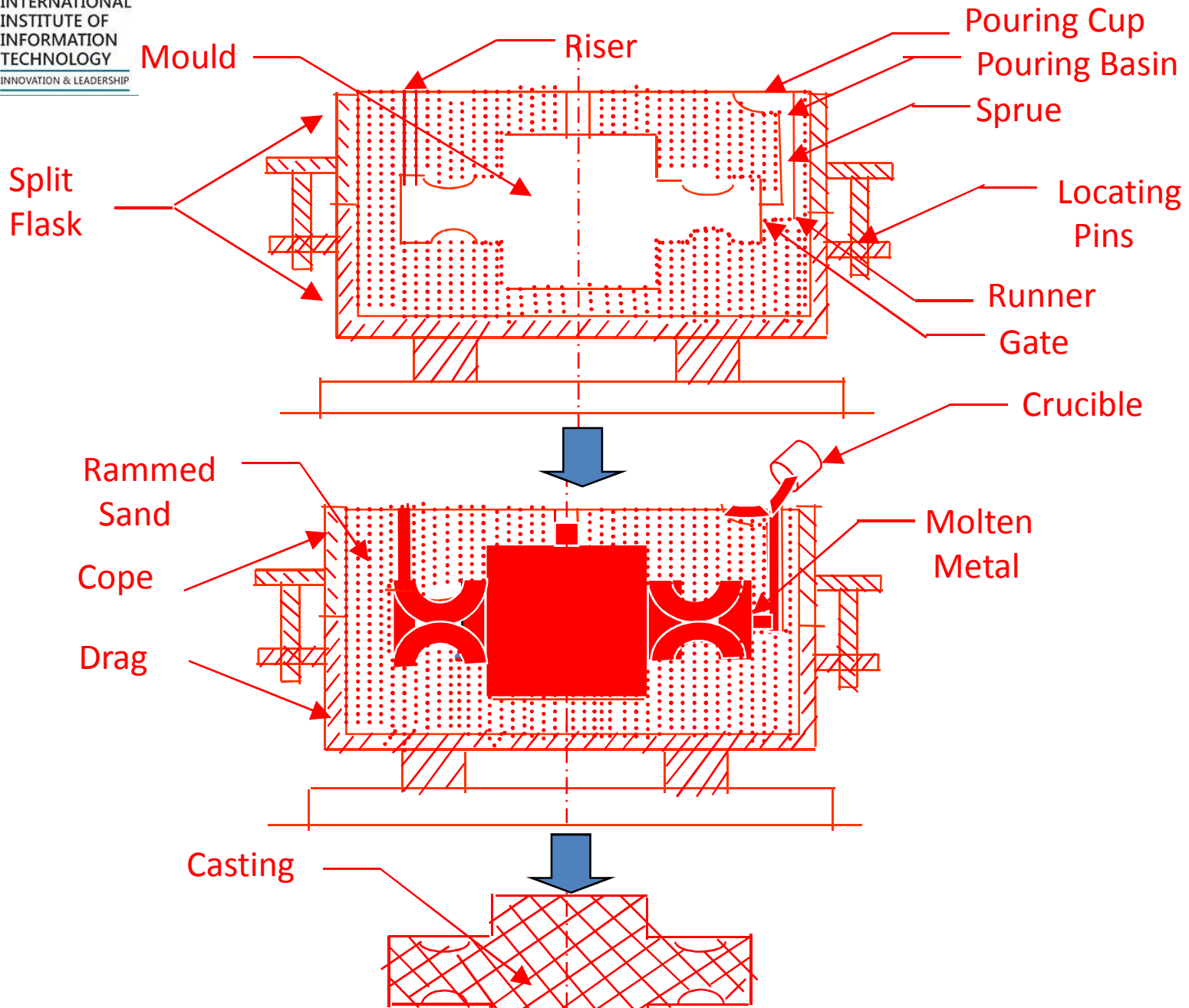

Steps in sand moulding

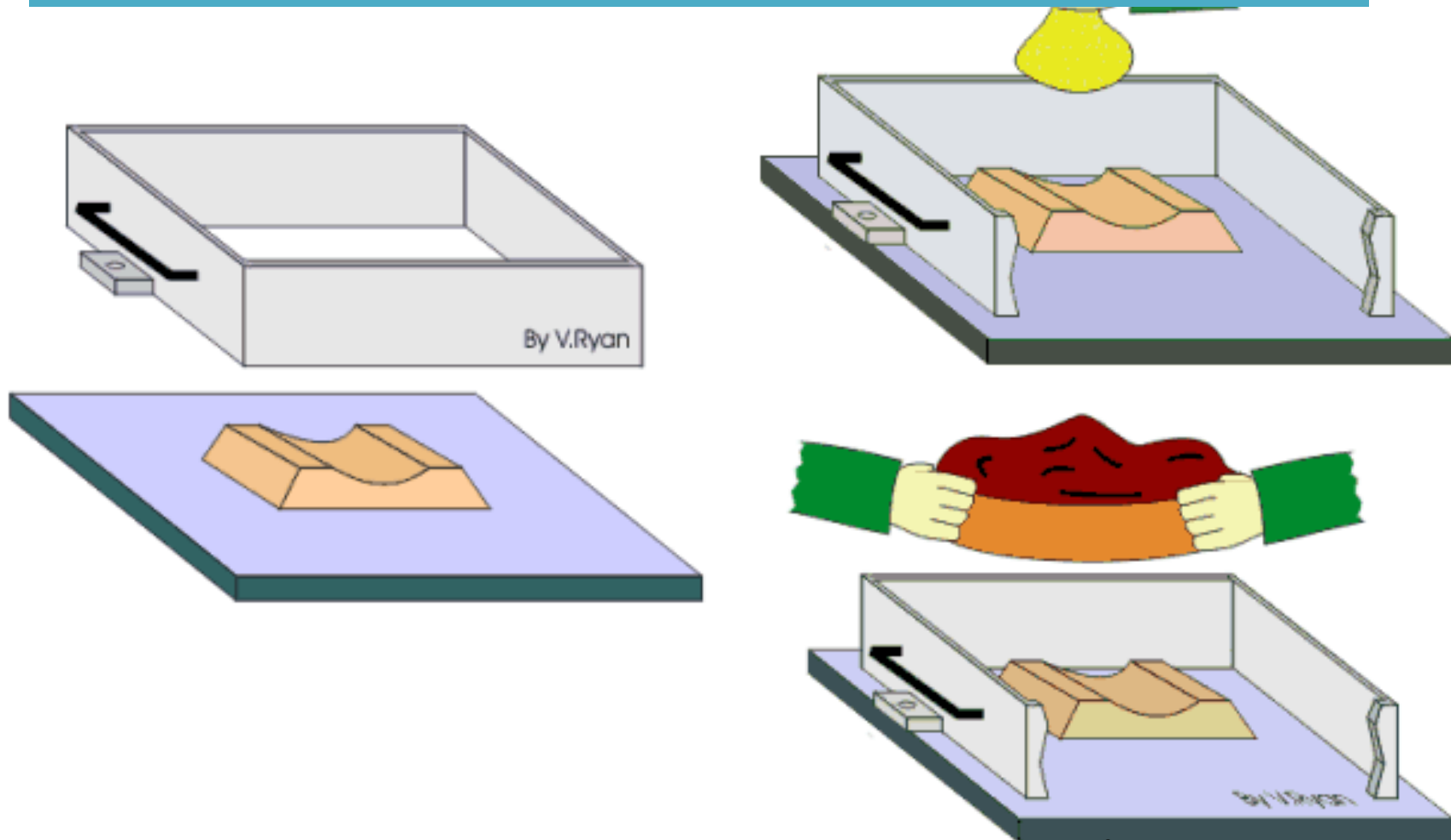

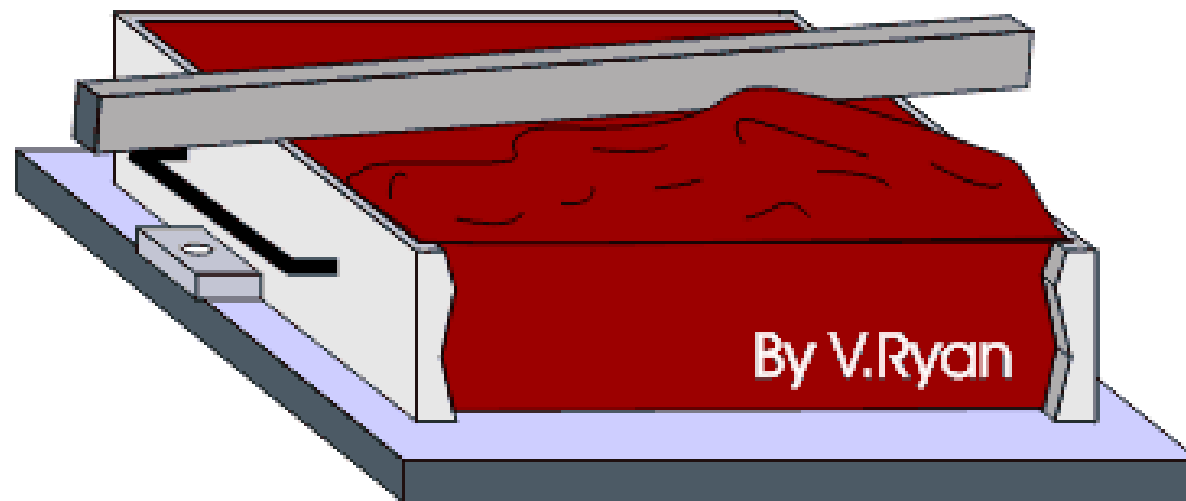
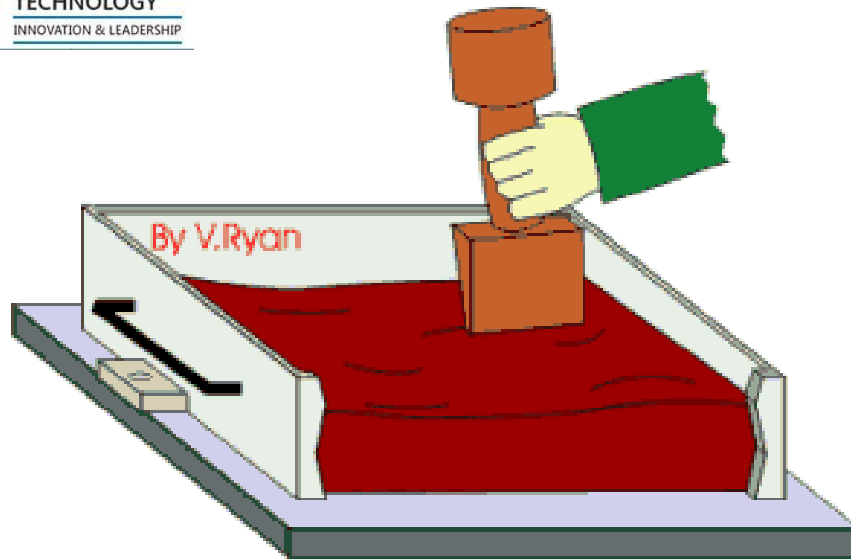

START

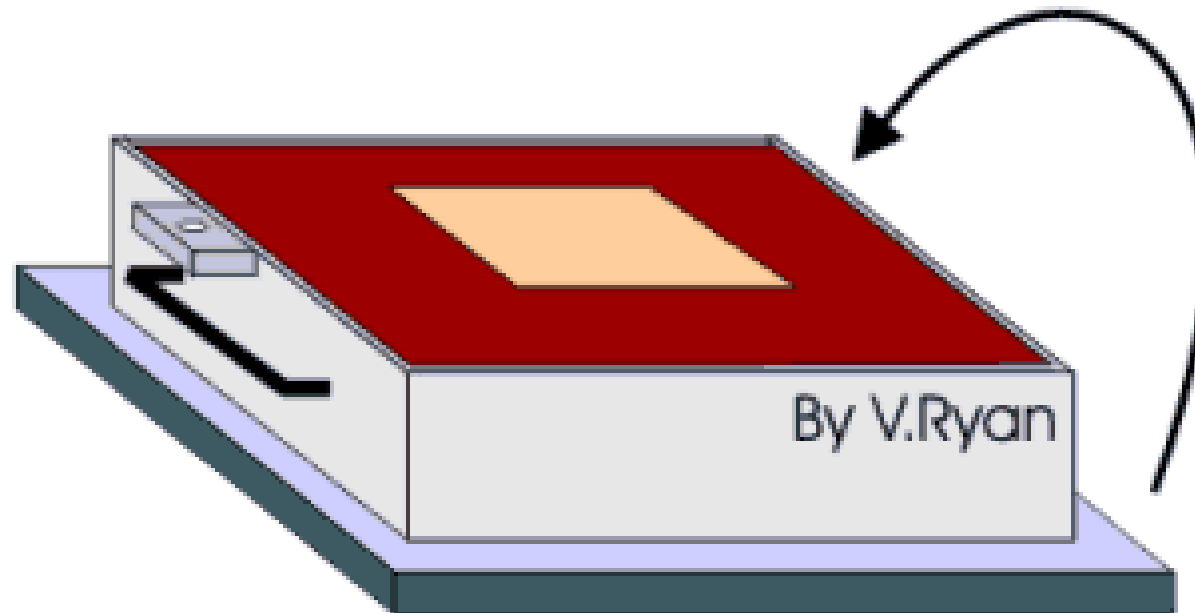
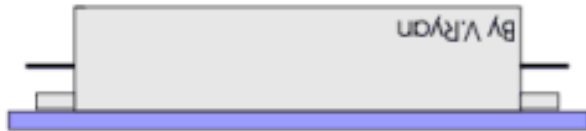

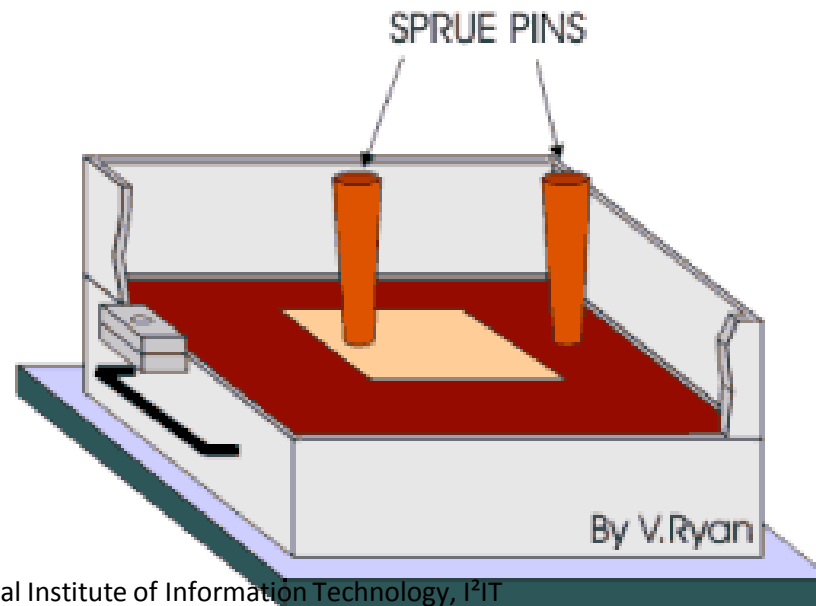
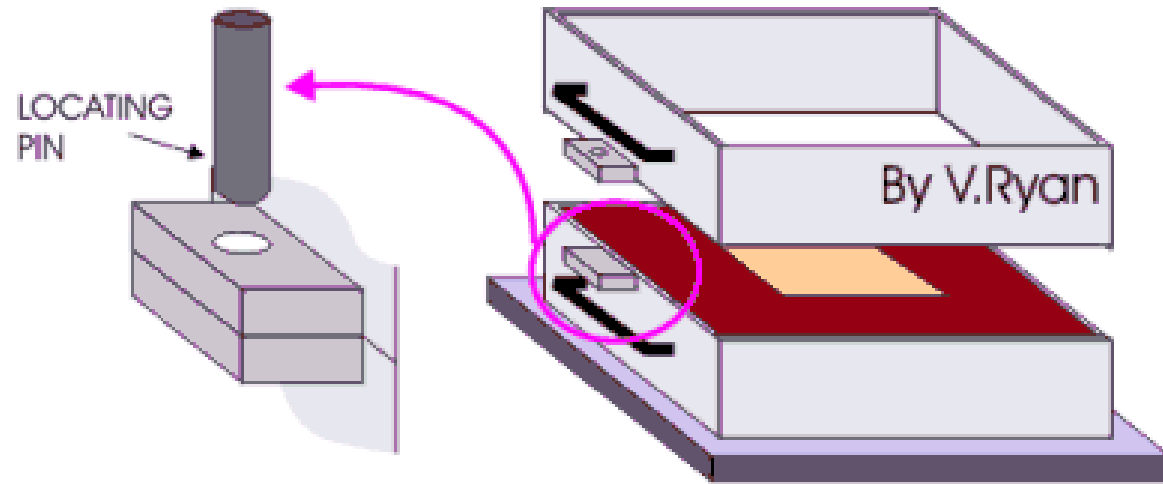

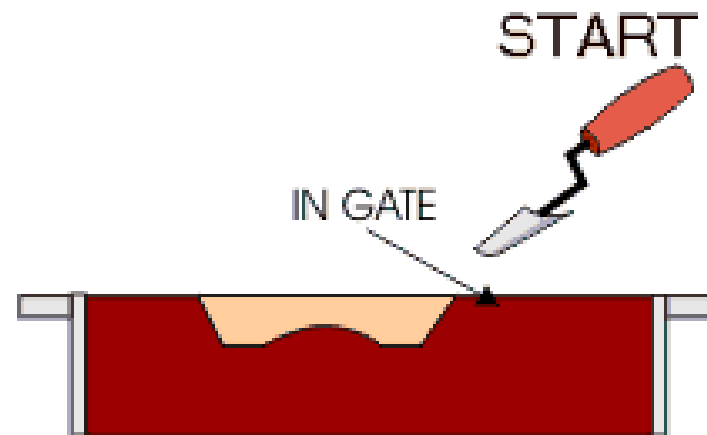
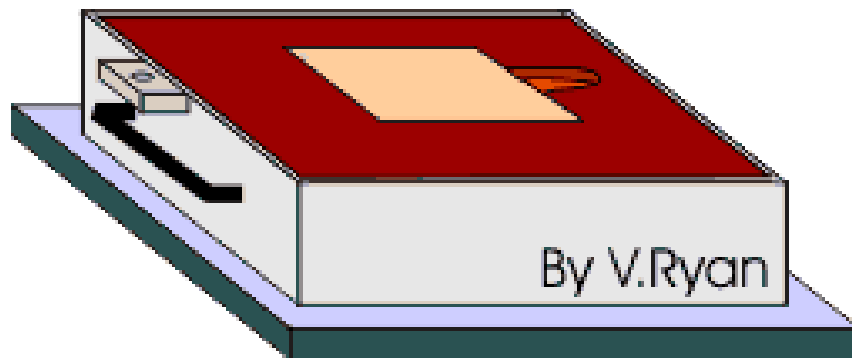
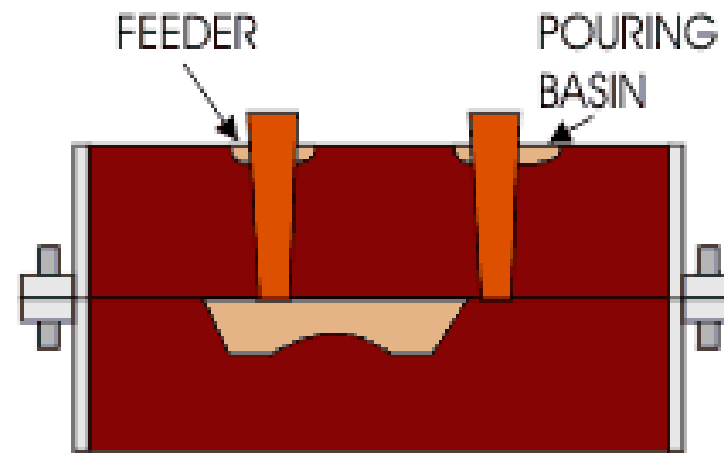
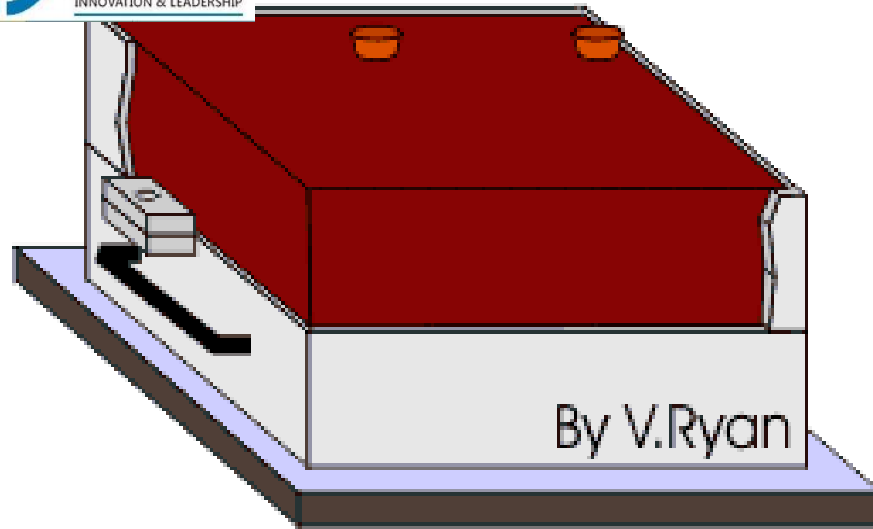

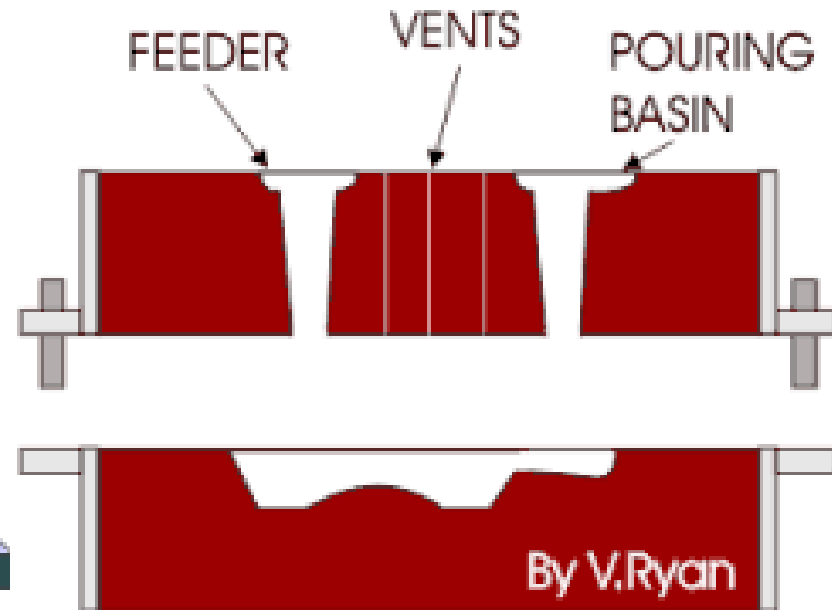
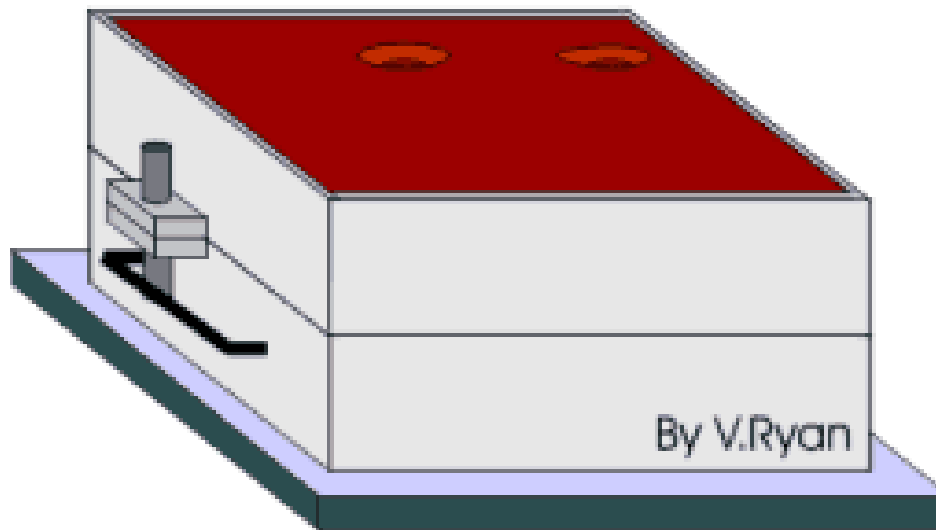
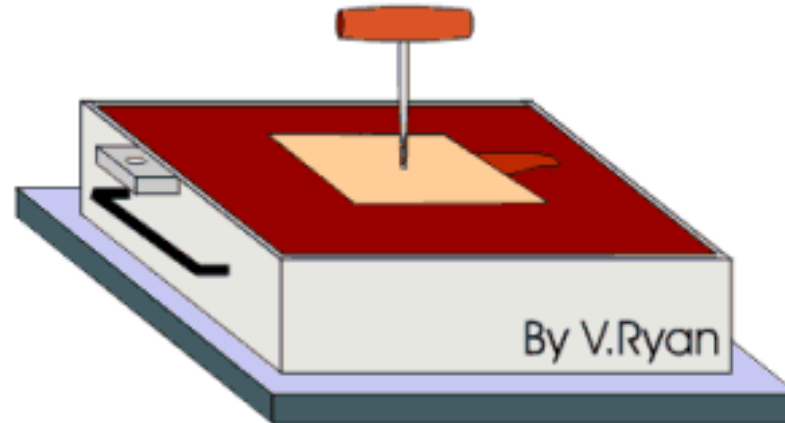

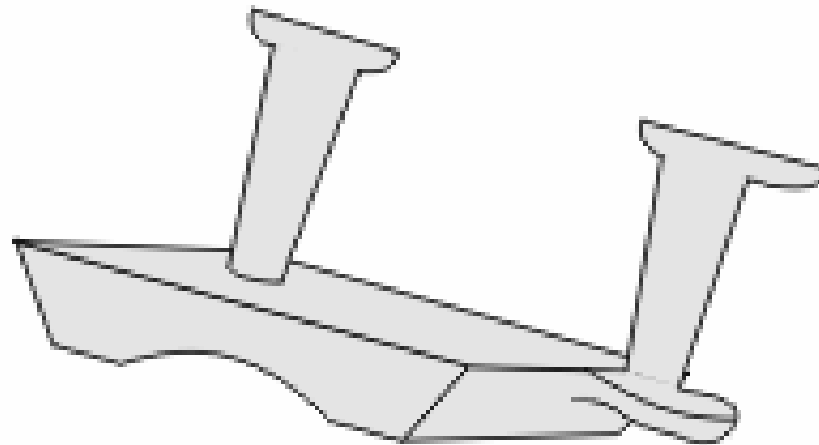
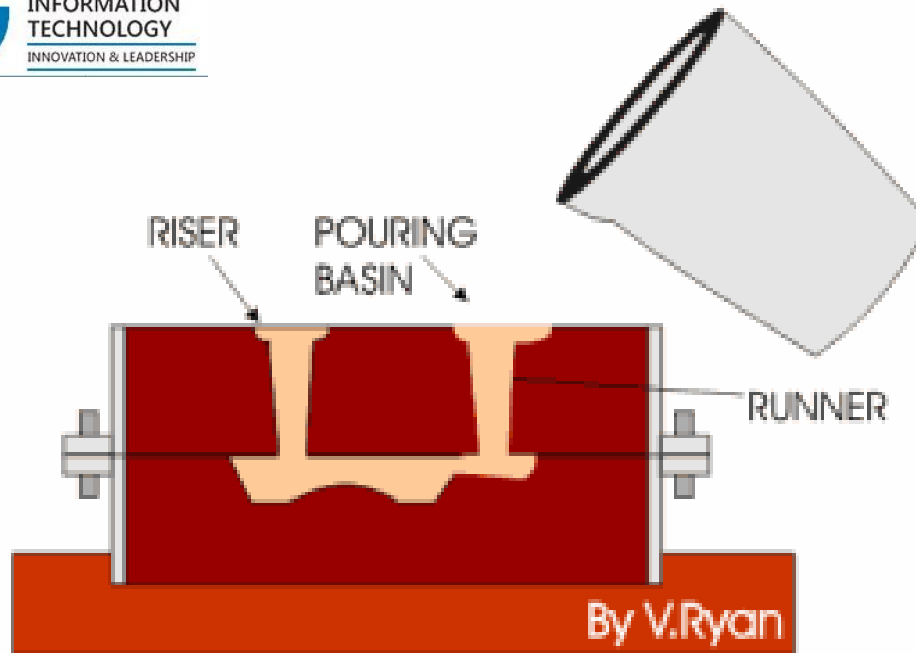

Metal Casting: Sand Casting

Applications of Sand Casting:

- . **Machine beds** for various machines (Lathe, Drilling, Shaping, Milling)
- . Automobile parts (Pistons, cylinder block, clutch and brake plates, Gearbox casing)
- . Aircraft parts (Turbine and compressor blades, Engine casing)
- . **Casings** used in various machines (Turbine, Generator, Compressors, Motors, Gear box, Pumps)
- . Pulleys, Railway wagon wheels, Valves

References

” V. Ryan © 2002 - 2018 www.technologystudent.com

Thank you

For further information please contact

Yogiraj Deshmukh
yogirajd@isquareit.edu.in

Department of Applied Sciences & Engineering
Hope Foundation's International Institute of Information
Technology, I²IT Pune
P-14, Rajiv Gandhi Infotech Park, MIDC Phase I,
Hinjawadi, Pune – 411 057

Phone - +91 20 22933441/2/3

www.isquareit.edu.in | info@isquareit.edu.in